

Marine GPS/VHF Antenna

MODEL: GVA-650

FOR Marine VHF Radio & AIS SYSTEM & Orbcomm



GPS Antenna Specifications: GA65

PHYSICAL CONDITION	
Constructions:	Polycarbonate radome, detachable cable/connector for easy mount, rubber-O-ring between top radome and screw base for waterproof
Dimensions:	60mm(Dia.) x 45mm(H)
Weight:	65grams (w/o cable & connector).
Color:	White or Black (Optional)
Mounting:	Bulkhead mount with 0.8 inch threaded wing nut (standard accessory).
Cable & Connector	
RF cable:	SMA(M)-10M RG58 -TNC(M) or Optional
Pulling strength:	6 Kg @ 5sec. molded plastic on connector end for strain relief.
Connector available:	SMA(F)
Antenna Element	
Center Frequency:	1575.42 MHz +/-1.023 MHz
Polarization:	R.H.C.P. (Right Handed Circular Polarization).
Absolute Gain @ Zenith:	+5 dBi typical.
Gain @ 10° Elevation:	-1 dBi typical.
Axial Ratio:	3 dB max.
Output VSWR:	2.0
Output Impedance:	50 ohm
Low Noise Amplifier	
Center Frequency:	1575.42 +/- 1.023 MHz
Power Gain:	28 db +/-3db
Bandwidth:	10 MHz min. @S11<=-10 dB
Noise Figure:	1.5
Outer Band Attenuation:	3 dB max.

BJTEK Navigation Inc. Supply Navigation	2.5~5.5V DC.	https://www.bjnav.com/
Current Consumption:	at 2.5V 6.6mA Typ. at 3.0V 8.6mA Typ. at 4.0V 12.6mA Typ. at 5.0V 16.6mA Typ.	
Filter	20dB 25dB @ fo+/- 50MHz 30dB 35dB @ fo+/- 100MHz * fo=1575.42MHz	
Overall Performance: (antenna element, LNA & coax cable)		
Center Frequency:	1575.42 +/- 1.023 MHz	
Gain:	At 90° vertical to sky 30 ± 4.5dBi (cable loss) Note:1 Mounted on the 60mm x 60mm square ground plane	
Noise Figure:	1.5 max.	
Axial Ratio:	3 dB max.	
Bandwidth:	10 MHz min. @S11≤-10 dB	
VSWR:	2.0 max.	
Output Impedance:	50 ohm	
Environmental		
Operating Temperature:	-40°C~ +100°C.	
Storage Temperature:	-40°C~ +100°C.	
Relative Humidity:	95% non-condensing.	
Water Resistance:	100% waterproof. IPX6	

Marine VHF Antenna Specifications: MVA-1400B

Marine VHF ANTENNA	
Fr :	156 ~ 165 Mhz
Gain:	3 ~6dB
Configuration :	1/2 wave
VSWR	2.0:1
Impedence:	50 ohm
Connector:	PL259(F) or N(F)
Ground	without
Dimension:	1380mm
Weight:	1Kg

* This specification is subject to change without prior notice

Data Updated: July.07, 2009

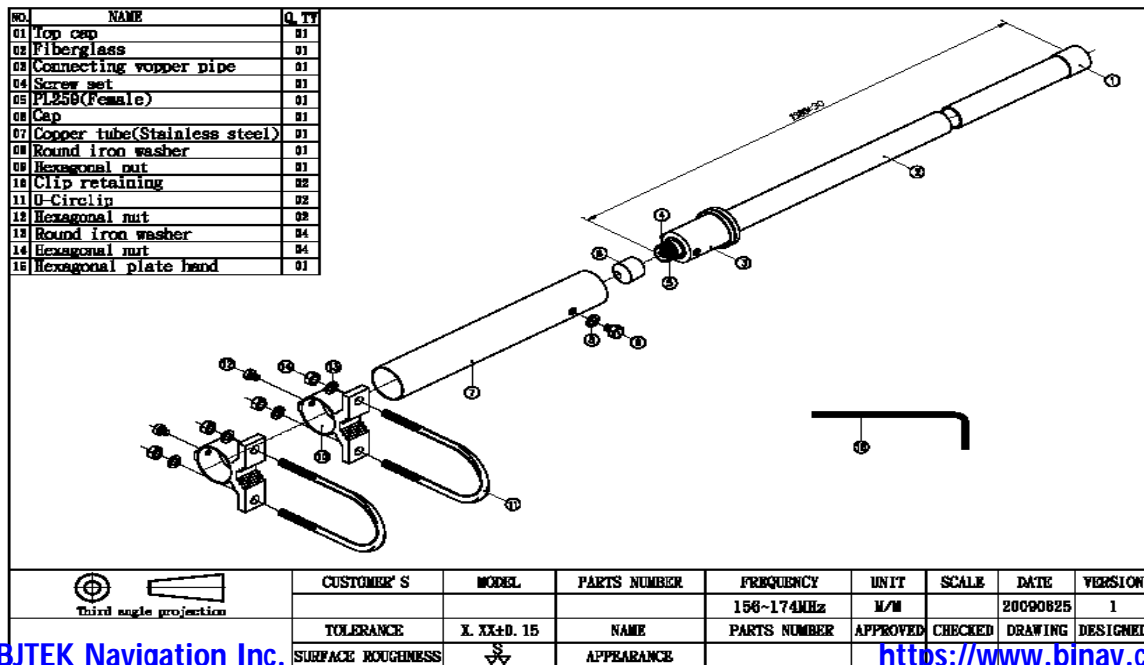
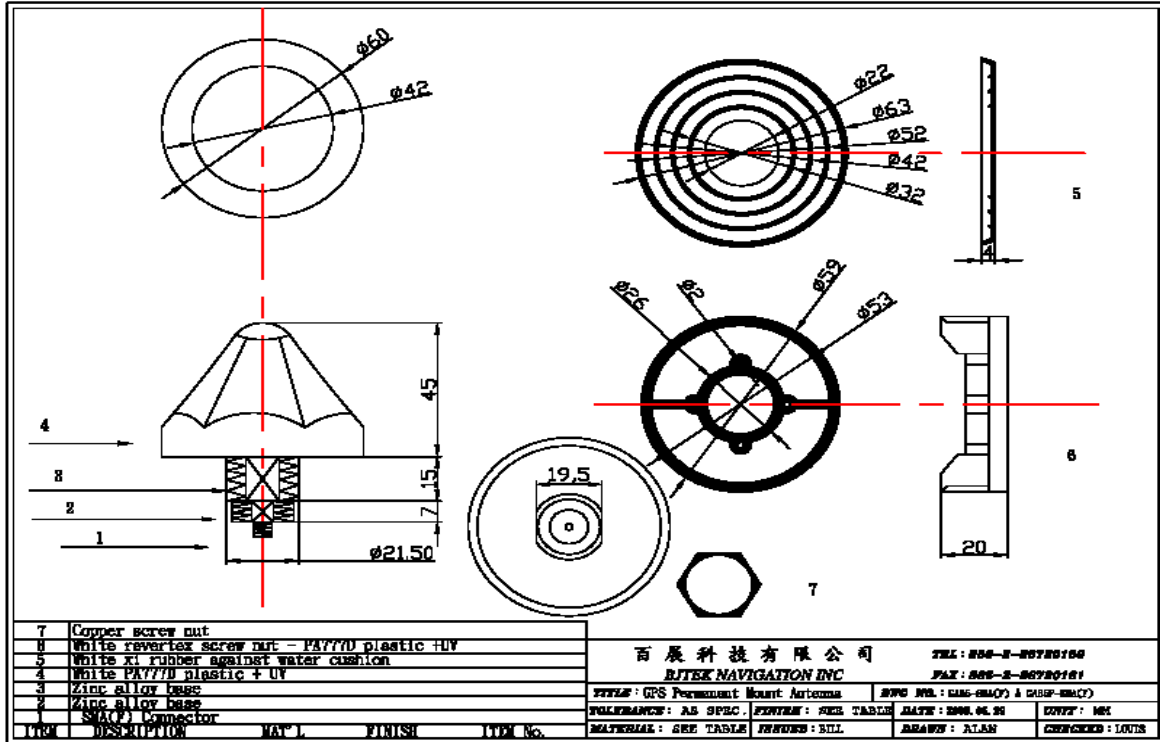

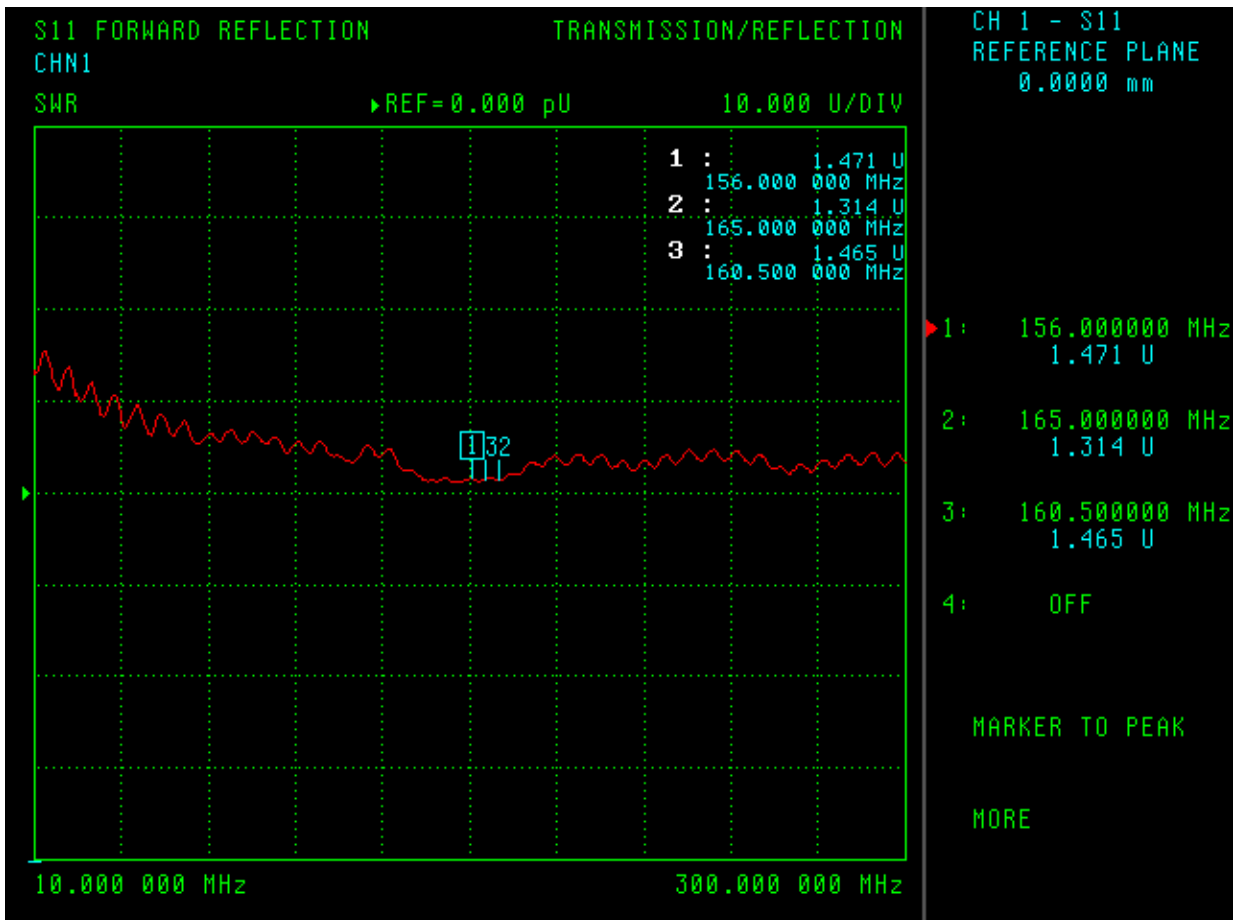
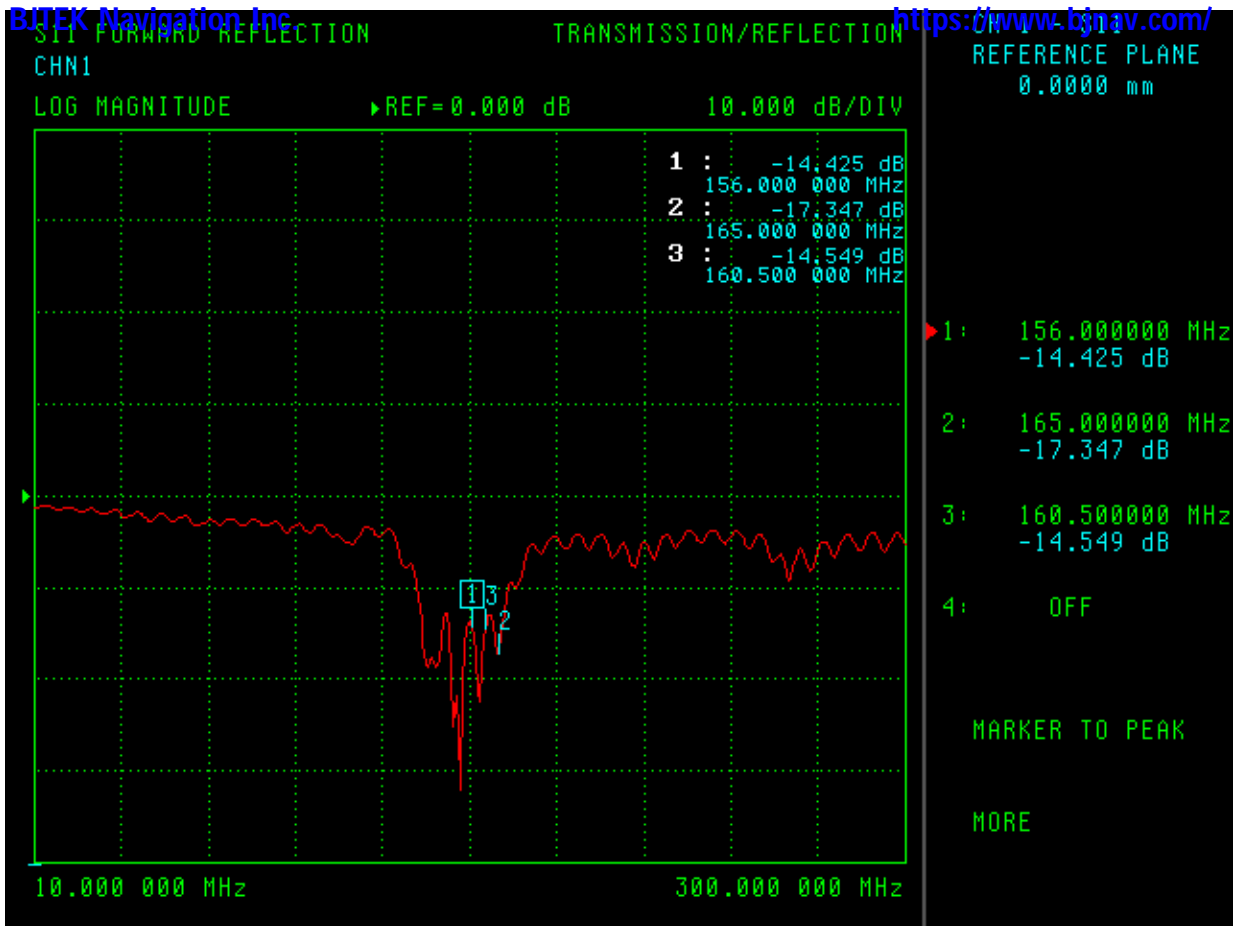

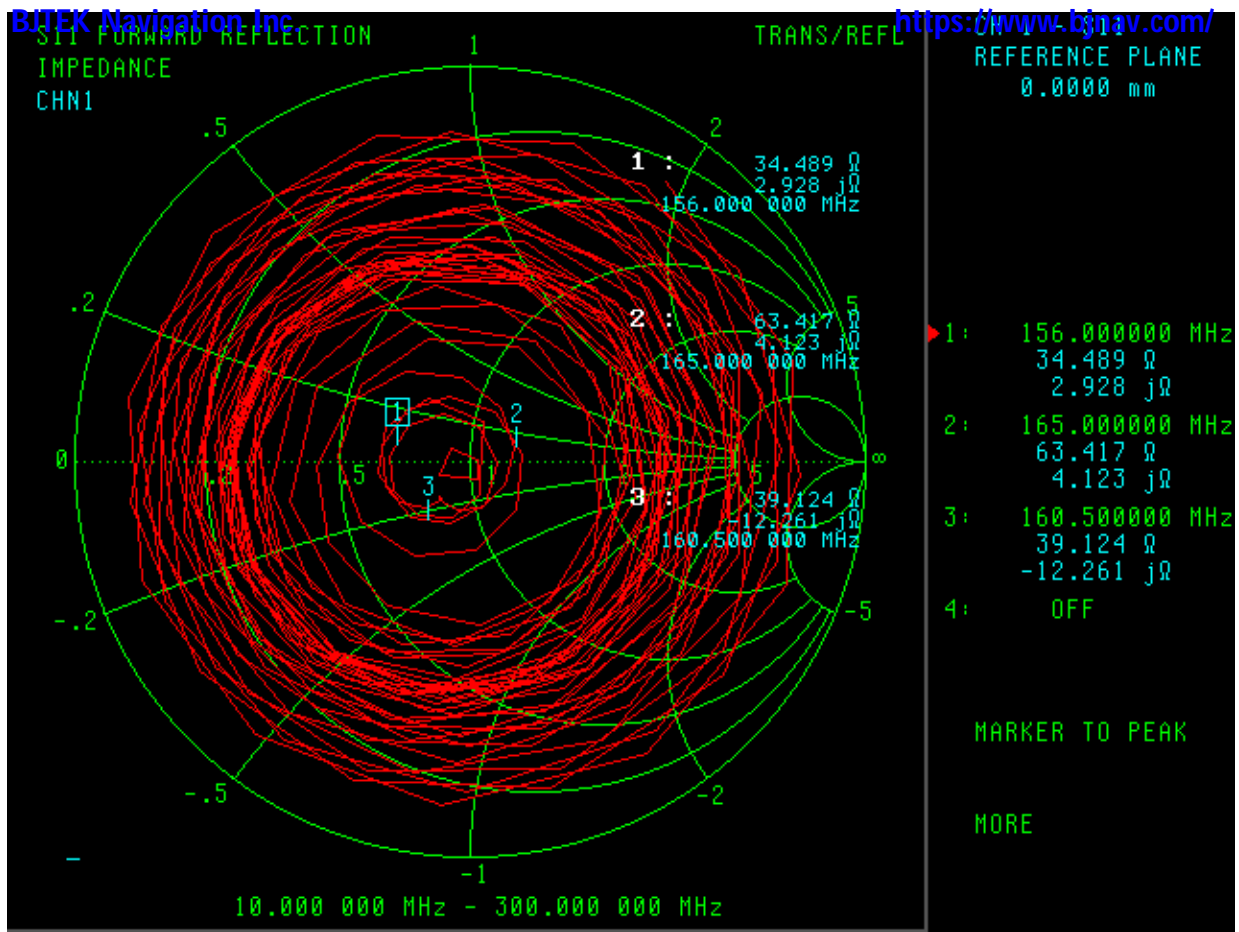

FB6 : SUS Base mounting

